

Enhanced Durability of Asphalt Pavements through Increased In-Place Pavement Density

Prepared by: Nye F. McCarty, P.E.
Flagstaff Regional Materials Engineer - Materials Group
Arizona Department of Transportation

Arizona Pavements/Materials Conference
November 21st, 2019
Arizona State University

Acknowledgements

- Tim Aschenbrener – FHWA Sr. Asphalt Pavement Engineer
- Febricio Leiva & Nam Tran – National Center for Asphalt Technology
- Ammon Heier – FHWA Arizona Division NC & SC Area Engineer
- Larry Galehouse – National Center for Pavement Preservation
- Paul Burch – ADOT Assistant State Materials Engineer (ret.) / Oregon DOT
- Dharminder (Paul) Sharma – ADOT Bituminous Engineer
- Fann Contracting, Inc.
- Fisher Sand & Gravel, Inc.
- Bob Humor – Asphalt Institute
- Chad Auker - ADOT NC District.

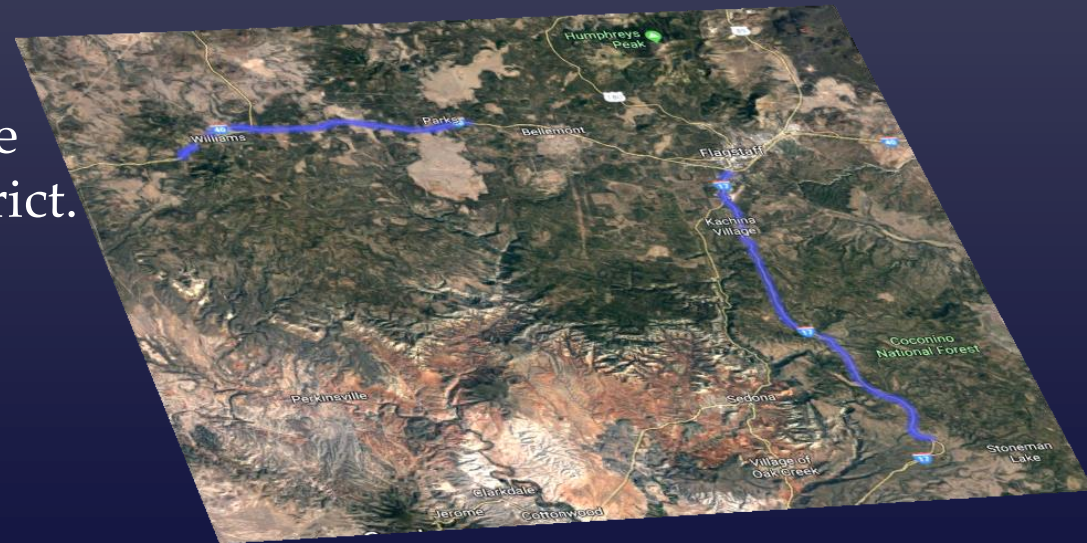

Increased Density (Compaction)

2018 Arizona Pavements/Materials Conference

FHWA's Demonstration Project for Enhanced Durability Through Increased Density



Courtesy Asphalt Institute

TIM ASCHENBRENER, P.E.
SENIOR ASPHALT PAVEMENT ENGINEER
PAVEMENT MATERIALS TEAM
OFFICE OF PRECONSTRUCTION, CONSTRUCTION AND PAVEMENTS
FHWA

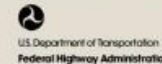

Increased Density (Compaction)

2018 Arizona Pavements/Materials Conference



- Hughes, C.S., "Compaction of Asphalt Pavement." NCHRP Synthesis 152, Washington, D.C., 1989.

- **Compaction is the single most important factor that affects pavement performance in terms of durability, fatigue life, resistance to deformation, strength and moisture damage.**

- Geller, M. Synthesis 152

- **"Compaction is the most economical alternative for achieving an increase in the life expectancy of new and rehabilitated pavement."**



- Brown, E.R., "Density of Asphalt Concrete – How Much is Needed?" NCAT Report 90-03. 1990.

- **"The amount of voids in an asphalt mixture is probably the single most important factor that affects performance throughout the life of an asphalt pavement. The voids are primarily controlled by asphalt content, compactive effort during construction, and additional compaction under traffic."**

NCAT Report No. 90-3

DENSITY OF ASPHALT
CONCRETE - HOW MUCH
IS NEEDED?

by

E. Ray Brown

Presented at the 69th Annual Meeting of the Transportation Research Board, Washington, DC, January 1990

Increased Density (Compaction)

2018 Arizona Pavements/Materials Conference

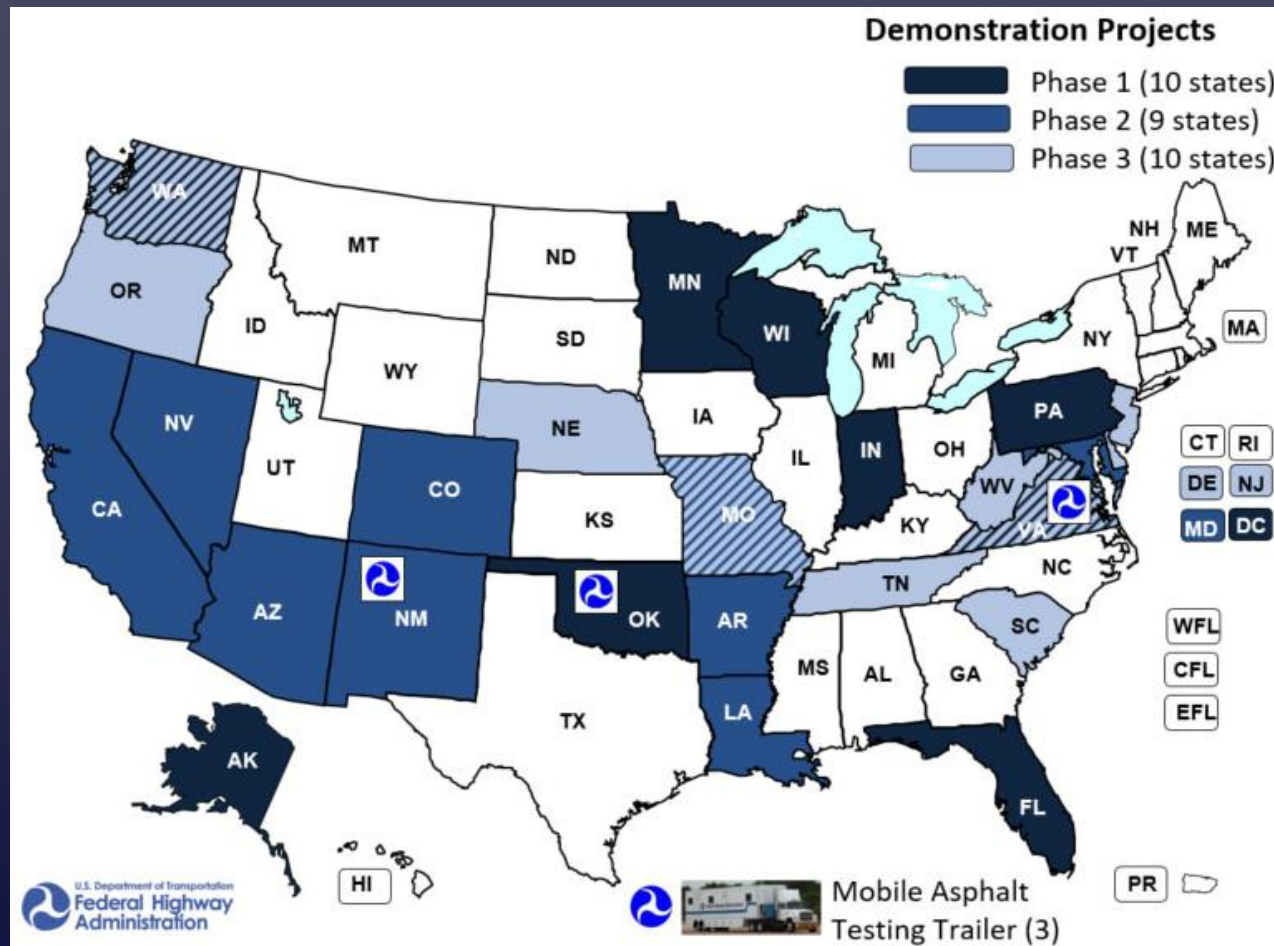

Increased Density

- Reduction of in-place air voids by increased compaction.
- Improves Pavement Performance
 - Increases Fatigue Resistance
 - Increases Durability
 - Increases Stability *
- Extends the life of the pavement
- A step toward sustainability

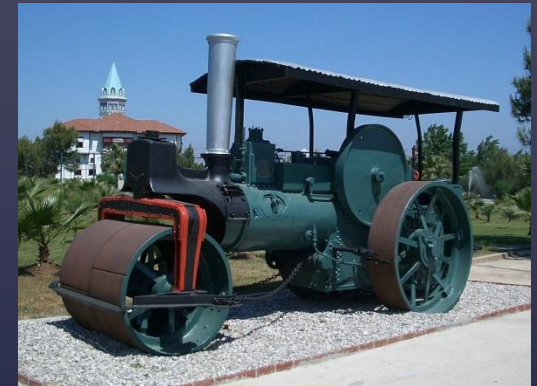

*provided volumetric properties are appropriate;
“over-compaction” and instability are a concern in Arizona

“Increased Density” & ADOT

- Stability in Arizona is **IMPORTANT**: It gets **HOT** here
- Pavements get **HOTTER**
 - Pavement surface can approach 180 deg. F
- “Standard” Density (ADOT)
 - Effective Voids at 5.5% (4.5% for Superpave)
 - In-Place Air Voids at 7.0% (max 9.0%)



ADOT starts I-17 project to improve travel to Flagstaff

Crews will repave, rebuild 28 miles northbound

April 25, 2018

PHOENIX – An Arizona Department of Transportation project scheduled to start Monday, April 30, will deliver a smoother driving surface along 28 miles of northbound Interstate 17 leading to Flagstaff, a stretch battered by repeated cycles of freeze and thaw during the winter.

Is Increased Density appropriate for hot, low elevation regions of the Desert Southwest?

Challenges w/ Standard ADOT Density

- High Effective Voids (mix voids):
 - generally result in higher in-place air voids
- Higher in-place air voids
 - increases the oxidation rate of asphalt binder
 - increases the moisture permeability of the pavement
- Increased Oxidation
 - stiffens/ages the asphalt binder
 - reduces fatigue resistance
 - reduces resistance to thermal shrinkage cracks
- Increased Moisture Permeability
 - increases the potential for stripping
 - reduces the durability of the mix
 - base / subgrade support failures
 - freeze-thaw damage

Challenges w/ Standard ADOT Density

- High Effective Voids (mix voids):
 - generally result in higher in-place air voids

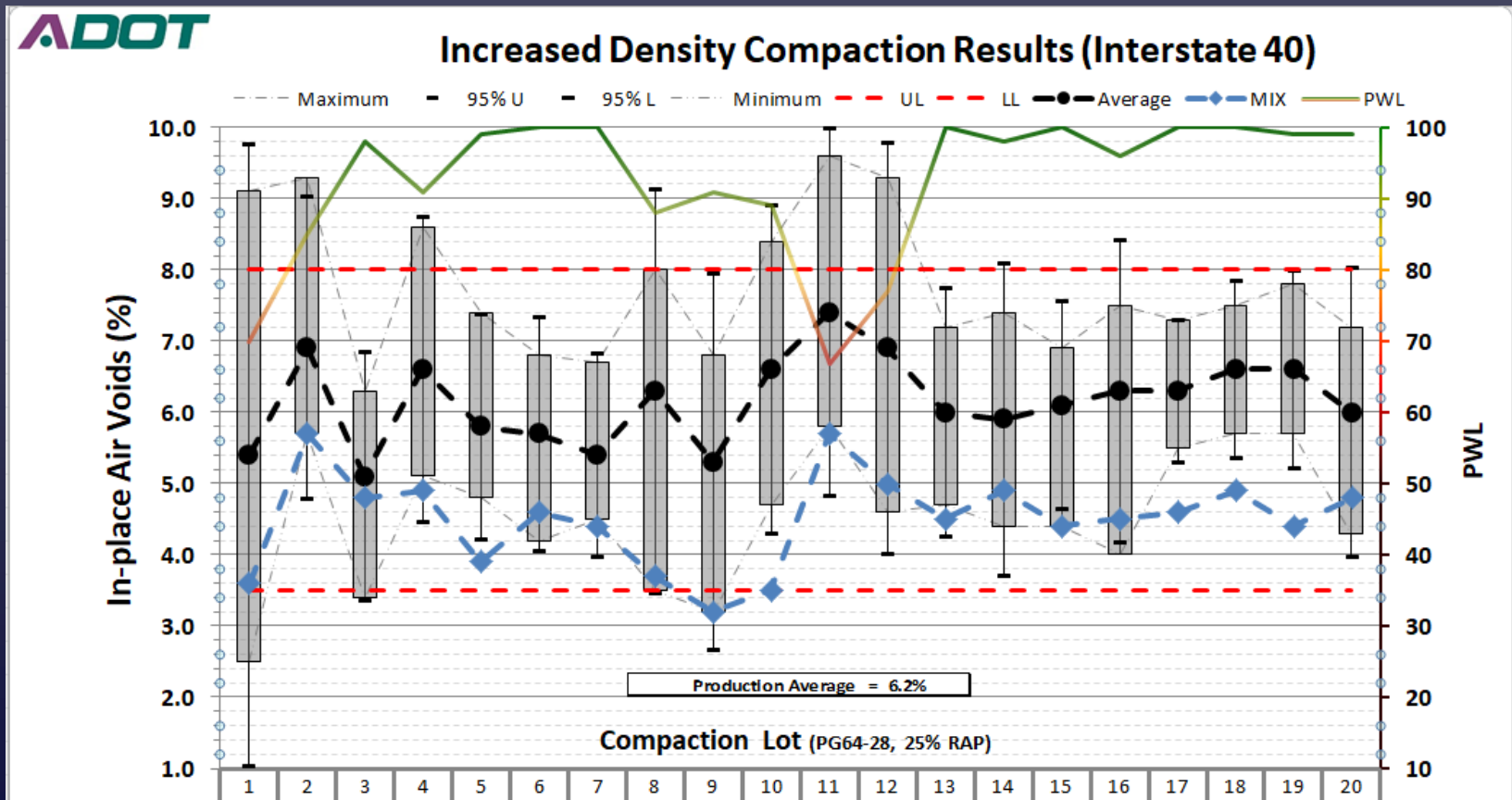

Challenges w/ Standard ADOT Density

- Higher in-place air voids (**interconnected** air voids)
 - Increased oxidation and moisture susceptibility

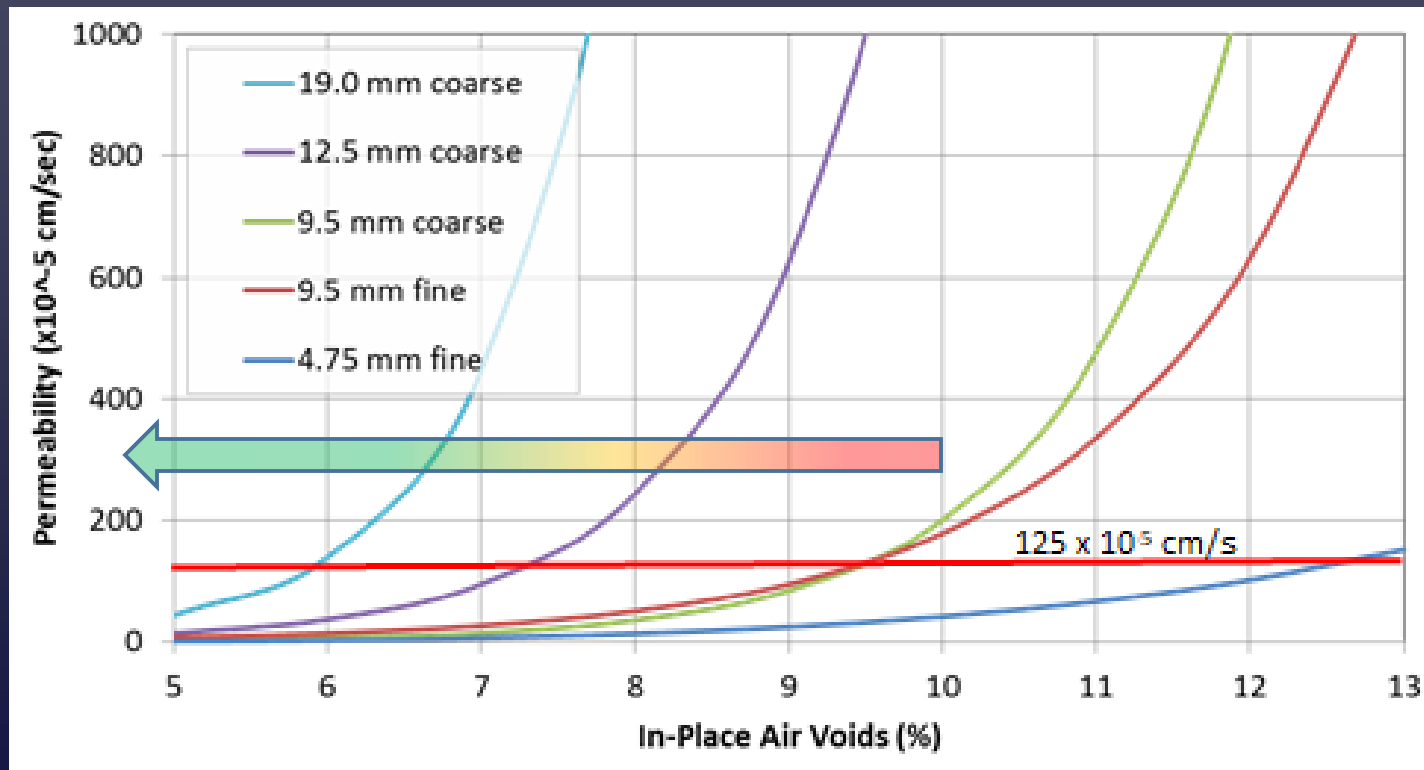

Source: NCAT Report 03-02

Challenges w/ Standard ADOT Density

- Increased Oxidation (accelerated aging)
 - Stiffens binder / reduces fatigue resistance
 - Thermal shrinkage cracking

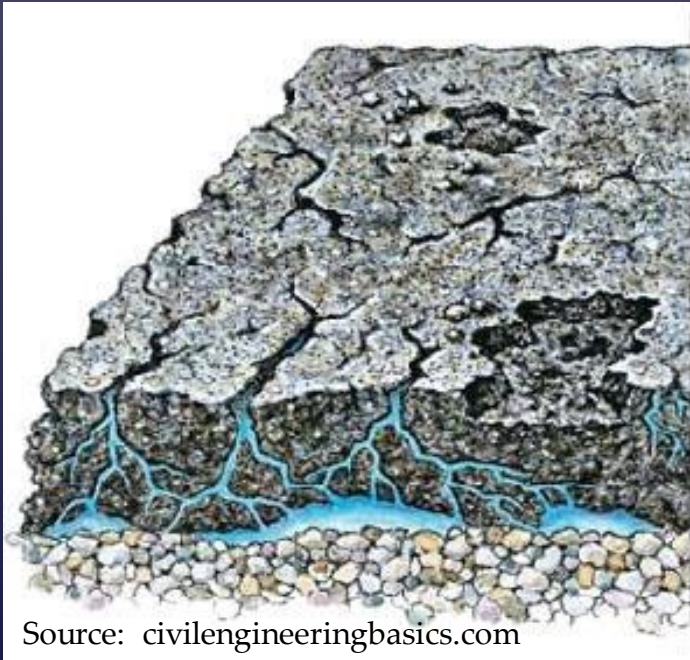

Challenges w/ Standard ADOT Density

- Increased Moisture Permeability
 - Stripping / Reduced Durability
 - Compromised Base/Subgrade Support
 - Freeze-thaw Damage
 - Rapid Deterioration



Increased Density Considerations

- Mix Design
- Compaction

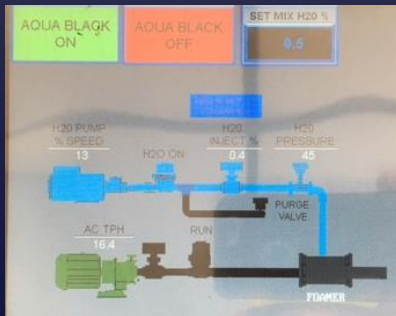
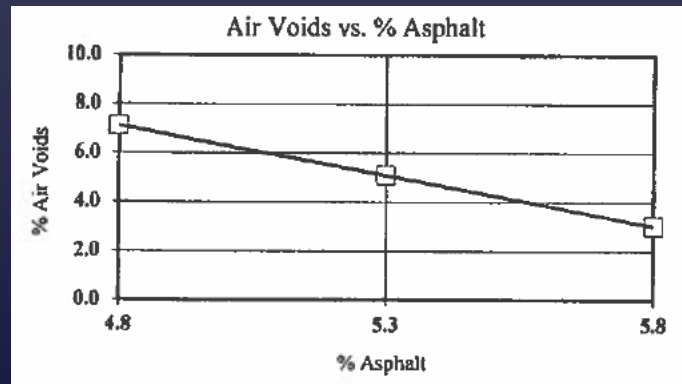
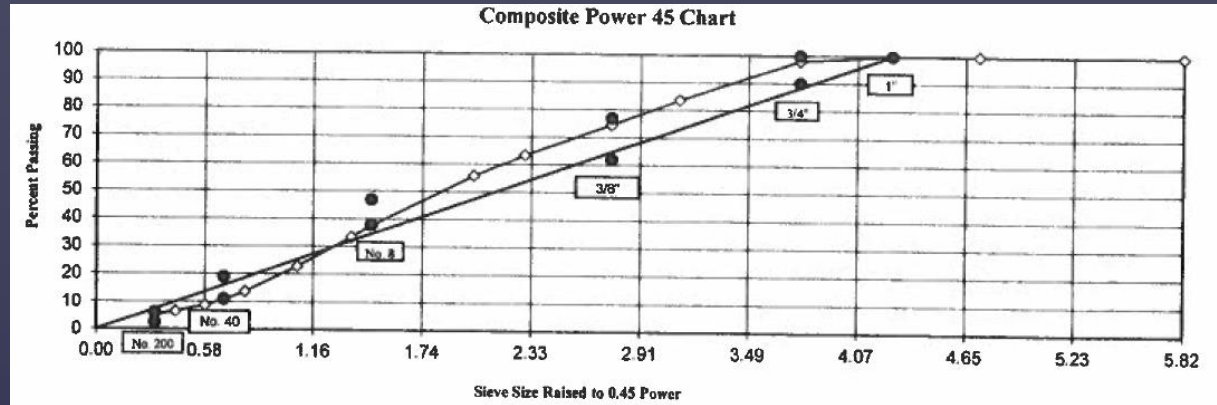

Increased Density – Mix Design

- Aggregate
 - Maintain Quality Indices
 - Reduce NMAS
- Adjust Mix / Volumetric Properties (within reason)
 - Lower Effective Voids
- Maintain Appropriate Volumetric Properties
 - Voids in Mineral Aggregate (VMA)
 - Voids Filled with Asphalt (VFA)
 - Dust/Effective Binder Ratio
- Performance Engineered (Balanced) Mix Design
 - Volumetric design / Performance based selection
- Superpave5 (Design at 5.0% Compact to 5.0%)
 - Gerry Huber – Heritage Research Group

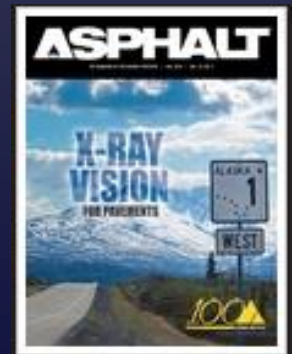

Increased Density – Mix Design

Illustration of Volumetric Parameters

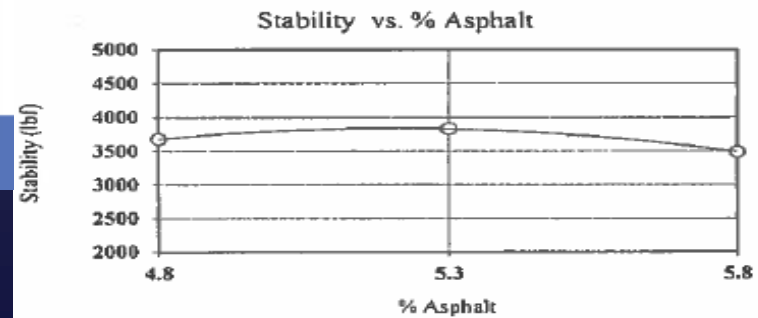
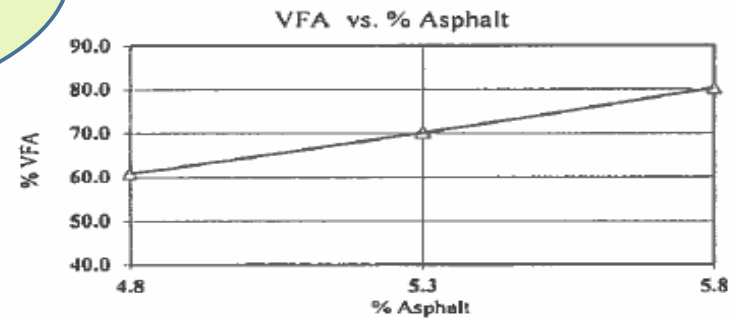
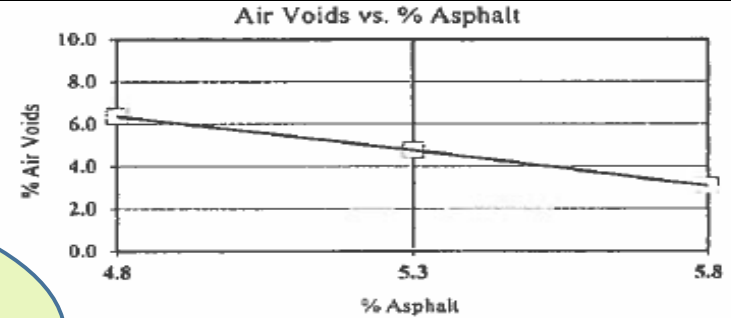
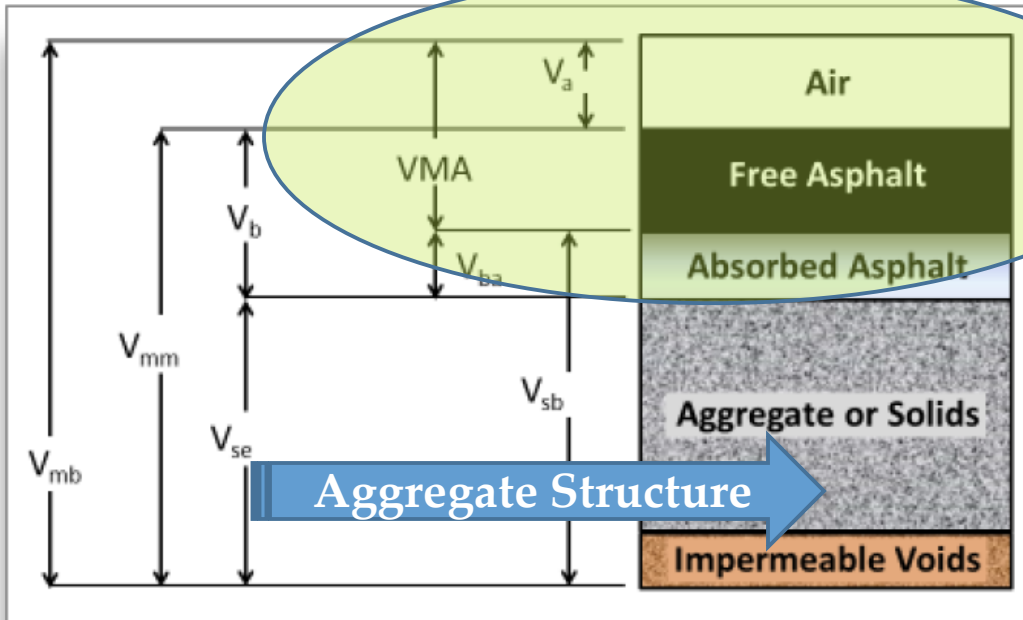

Increased Density – Mix Design

- Voids in Mineral Aggregate (VMA) is an important volumetric property

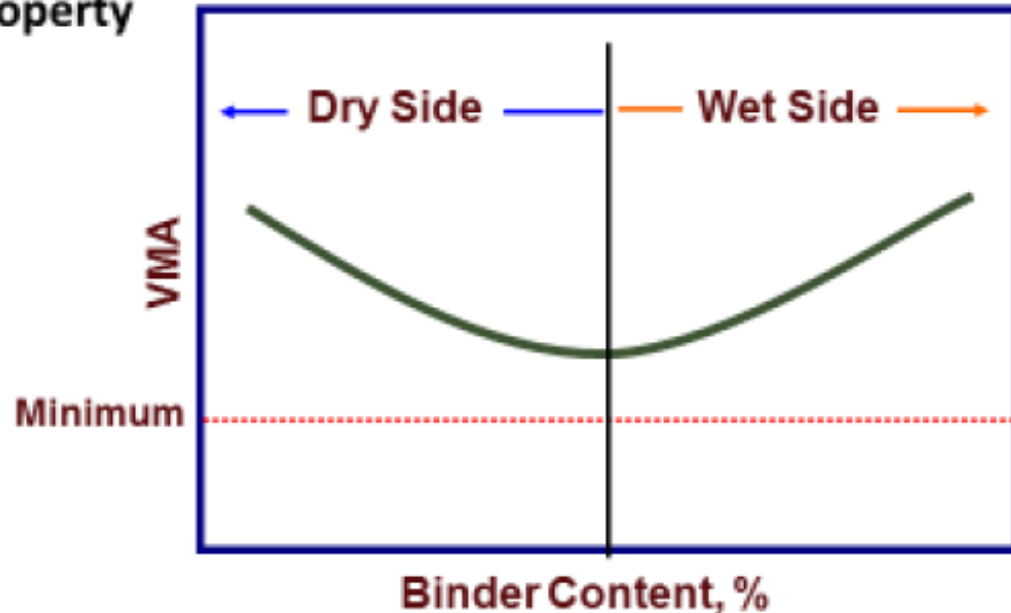

- Do **not** select target binder content on the “wet side” of VMA curve. Why?



Increased Density – Mix Design

Voids in Mineral Aggregate (VMA) Design Criterion:

NMAS, mm	Minimum VMA, %
9.5	15.0
12.5	14.0
19	13.0
25	12.0
37.5	11.0

VMA

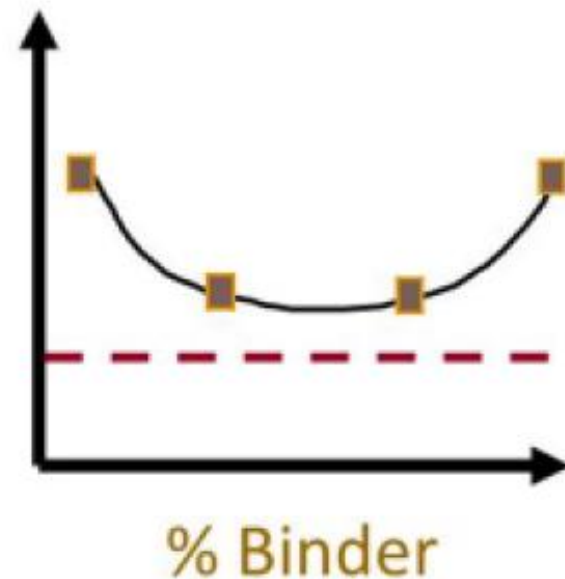

Increased Density – Mix Design

- **Void Filled with Asphalt (VFA) Criterion:**

Design ESALs, 10^6	Range of VFA, %
< 0.3	70 to 80
0.2 to < 3.0	65 to 78
3.0 to < 30	65 to 75
> 30	65 to 75

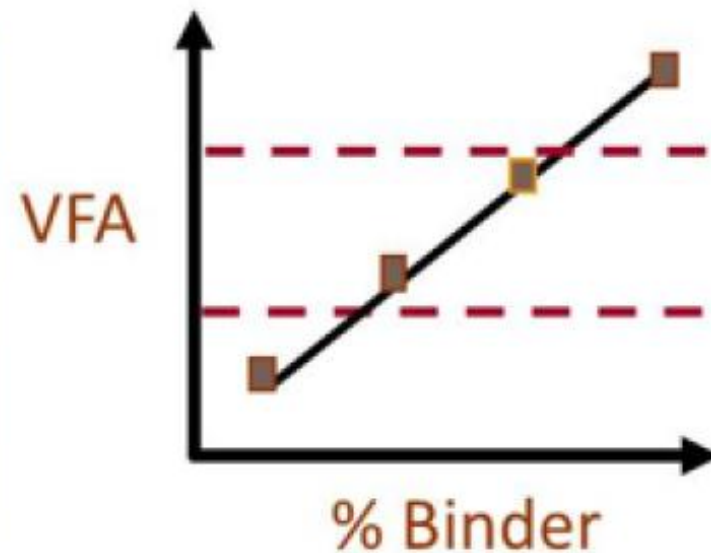

Increased Density - Compaction

- More Roller Passes / More Rollers
 - Slow down the speed of the rollers (impacts/foot)
!!do not reduce lift thickness!!
- Warm Mix Additive as a Compaction Aid
 - Maintain production temperature
- Quality Control
 - Aggregate Production
 - Mixture Production
 - Compaction (Intelligent Compaction)
- Adjustments During Production
 - Asphalt Content / Bin Percentages
 - Bailey Method

Increased Density - Resources

- National Center For Asphalt Technology (NCAT)
<http://eng.auburn.edu/research/centers/ncat/newsroom/2016/enhanced-compaction>

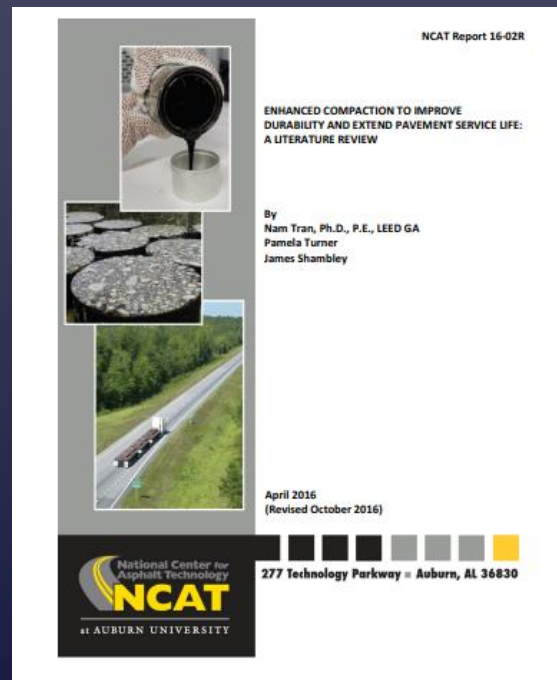

[NCAT Report 16-02R](#)

Increased Density - Resources

- Asphalt Institute

<http://www.asphaltinstitute.org/download/309/>

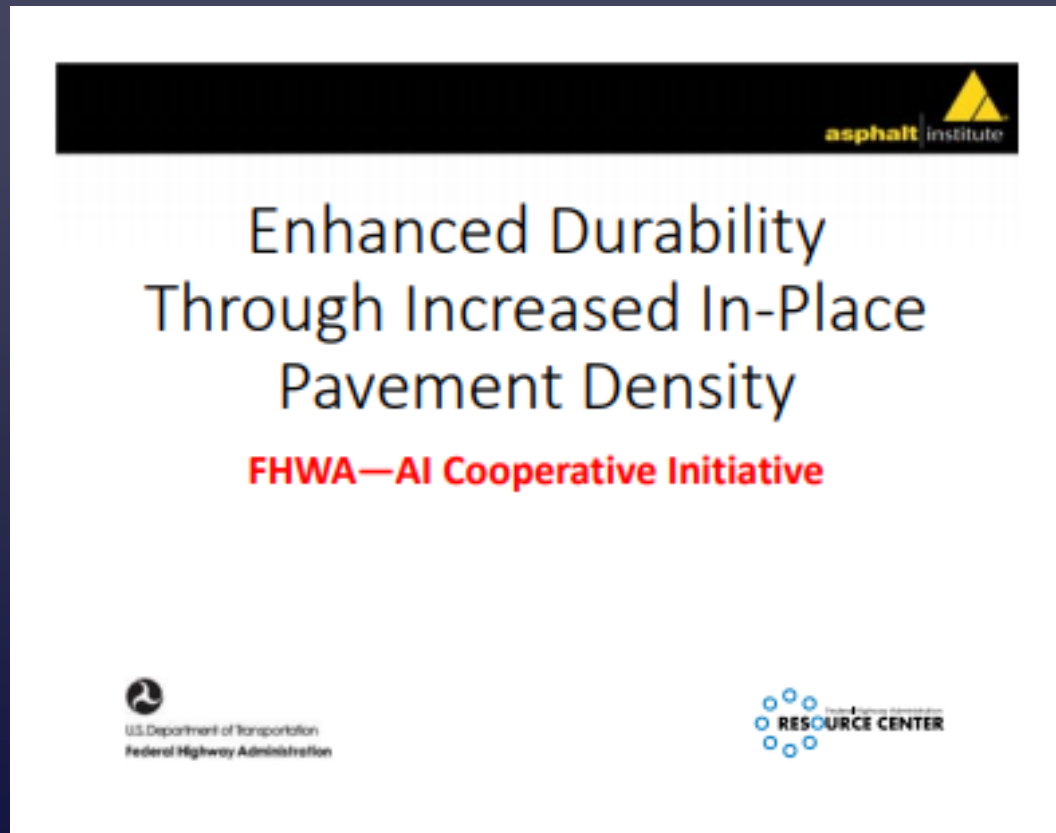

Increased Density - Resources

- FHWA

<https://www.fhwa.dot.gov/pavement/asphalt/density/demo.cfm>

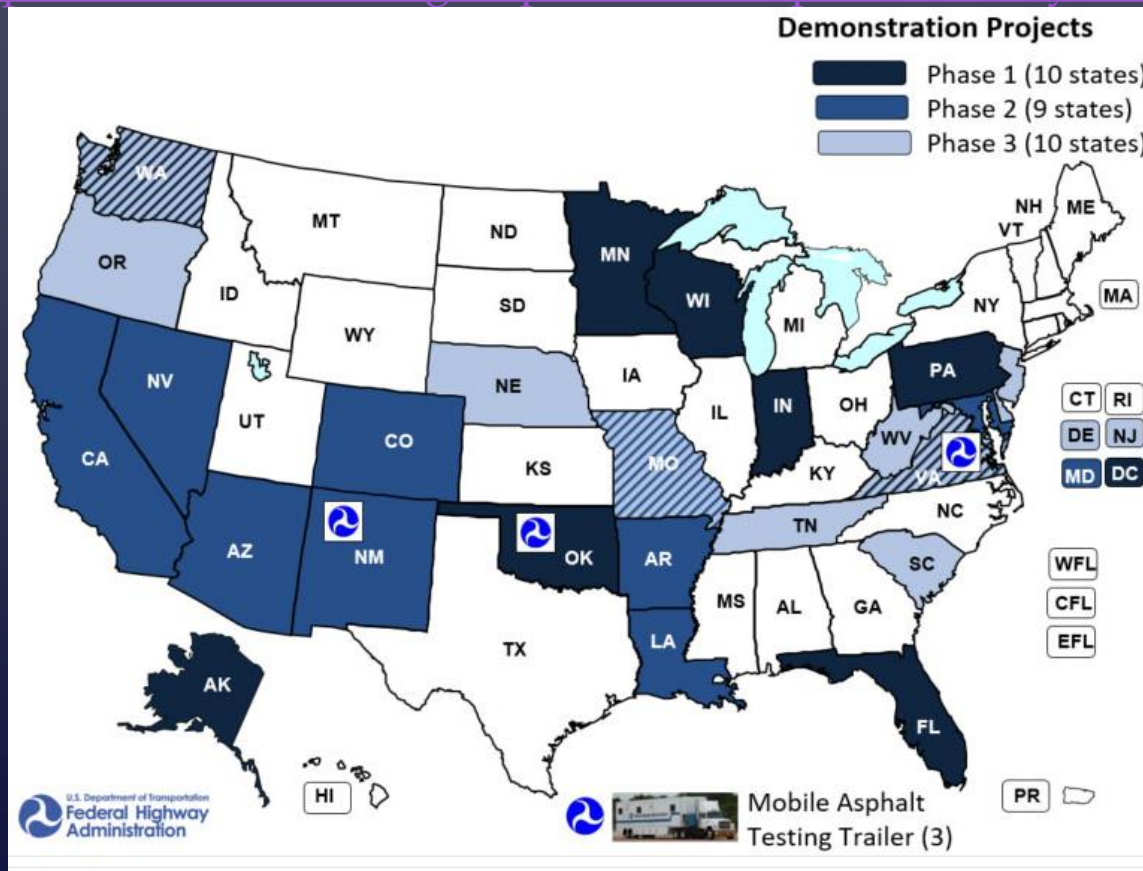

NCAT Report 17-05

DEMONSTRATION PROJECT FOR ENHANCED DURABILITY OF ASPHALT PAVEMENTS THROUGH INCREASED DENSITY

By
Tim Aschenbrener
E. Ray Brown
Nam Tran
Phillip B. Blankenship

July 2017

National Center for Asphalt Technology
NCAT
AT AUBURN UNIVERSITY

277 Technology Parkway • Auburn, AL 36830

FHWA Demonstration Project for Enhanced Durability of Asphalt Pavements through Increased In-place Pavement Density, Phase 2

FHWA-HF-15-052

May 2015

U.S. Department of Transportation
Federal Highway Administration

Increased Density - ADOT

- Demonstration Project(s) – 2018 End Product AC
 - I-40 Cataract Lake Road to Parks TI (official)
 - I-17 (NB) Coconino County Line to I-40 (unofficial)
- Baseline Projects – All 2017 End-Product AC Statewide
 - Over 900 Lots of AC
 - Approximately 1.8 Million Tons of AC
 - Over 9,000 AC Cores
- Select Projects from Prior Years
 - I-40 Walnut Canyon to Twin Arrows
 - I-40 Parks TI to Riordan Bridge
 - I-17 New River Rd to Coldwater Lane

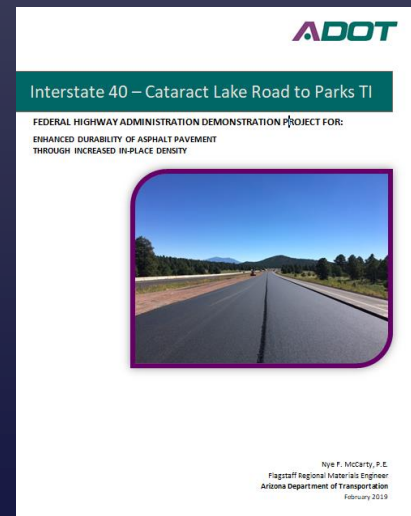

Increased Density - ADOT

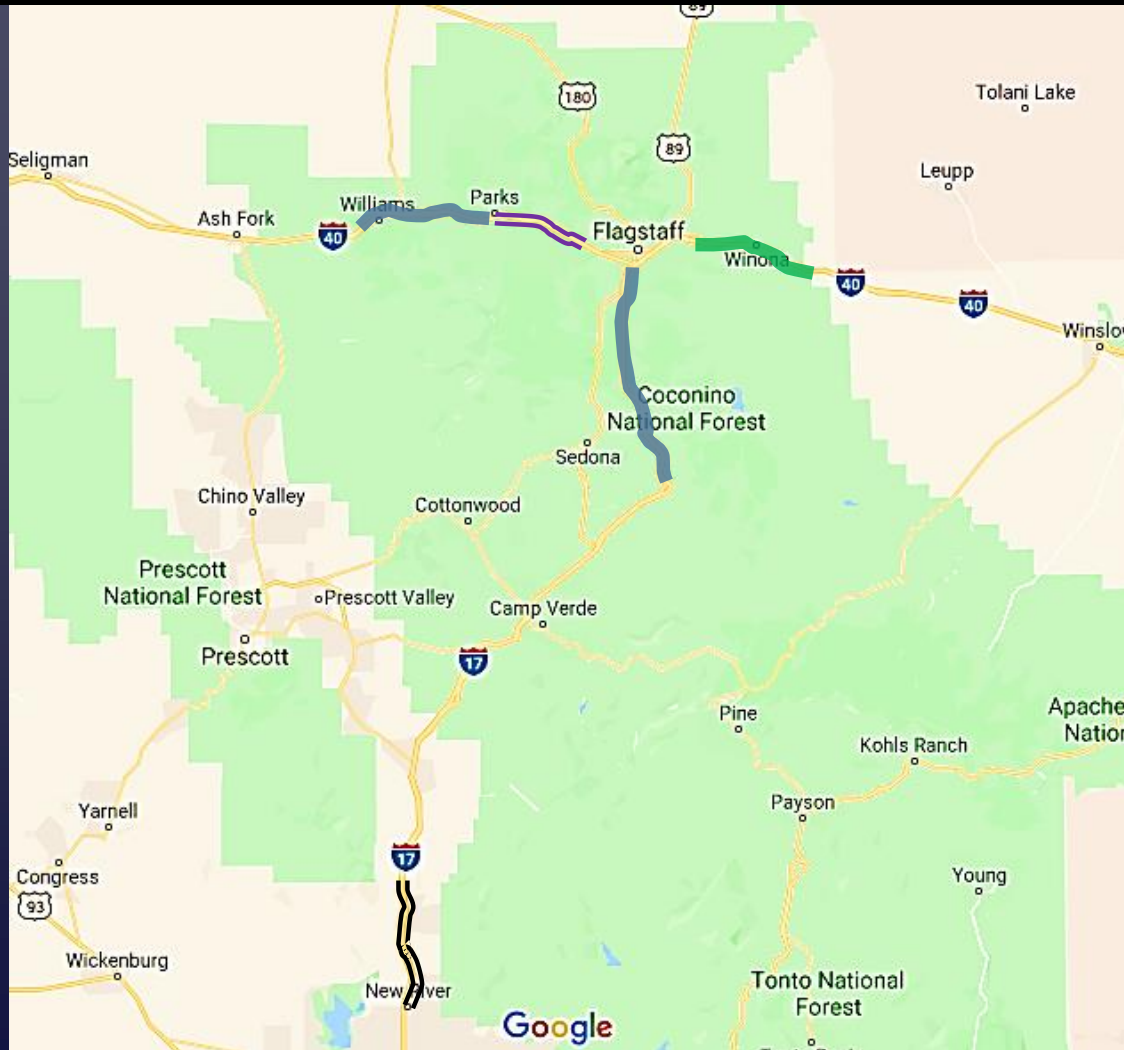

I-40 Cataract Lake Road to Parks TI



Google

Increased Density - ADOT

- I-40 Cataract Lake Road to Parks TI
 - Official FHWA Increased Density Demonstration Project
 - MP 162 to MP 179 (17 miles)
 - Two Reconstruction Sections - Cement Treated Subgrade
 - Davenport Lake (5-miles)
 - Parks (1-mile)
 - First reconstruction along this segment of I-40
 - 353,245 tons of End Product AC (237,543 included in ADOT study)
 - Warm Mix Additive and SBS polymer modified asphalt upper 2"

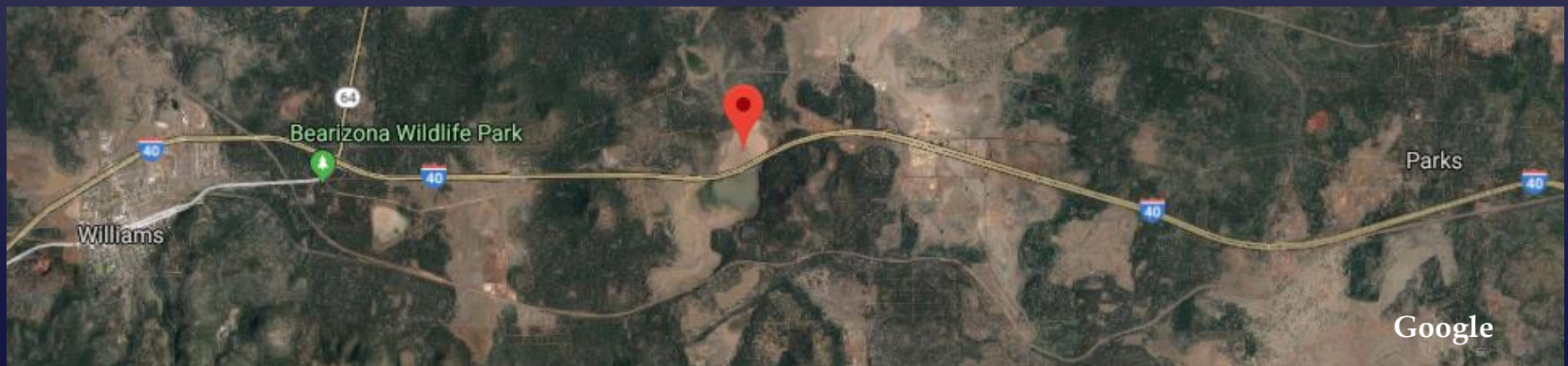

I-40 Cataract Lake Road to Parks TI

- Two Segments of Significantly Deteriorating Pavement
 - MP 167 to MP 172 (Davenport Lake)
 - MP 178 to MP 179 (Parks)



I-40 Cataract Lake Road to Parks TI

- Deteriorating Pavement



I-40 Cataract Lake Road to Parks TI

- Reconstruction: Pavement Section

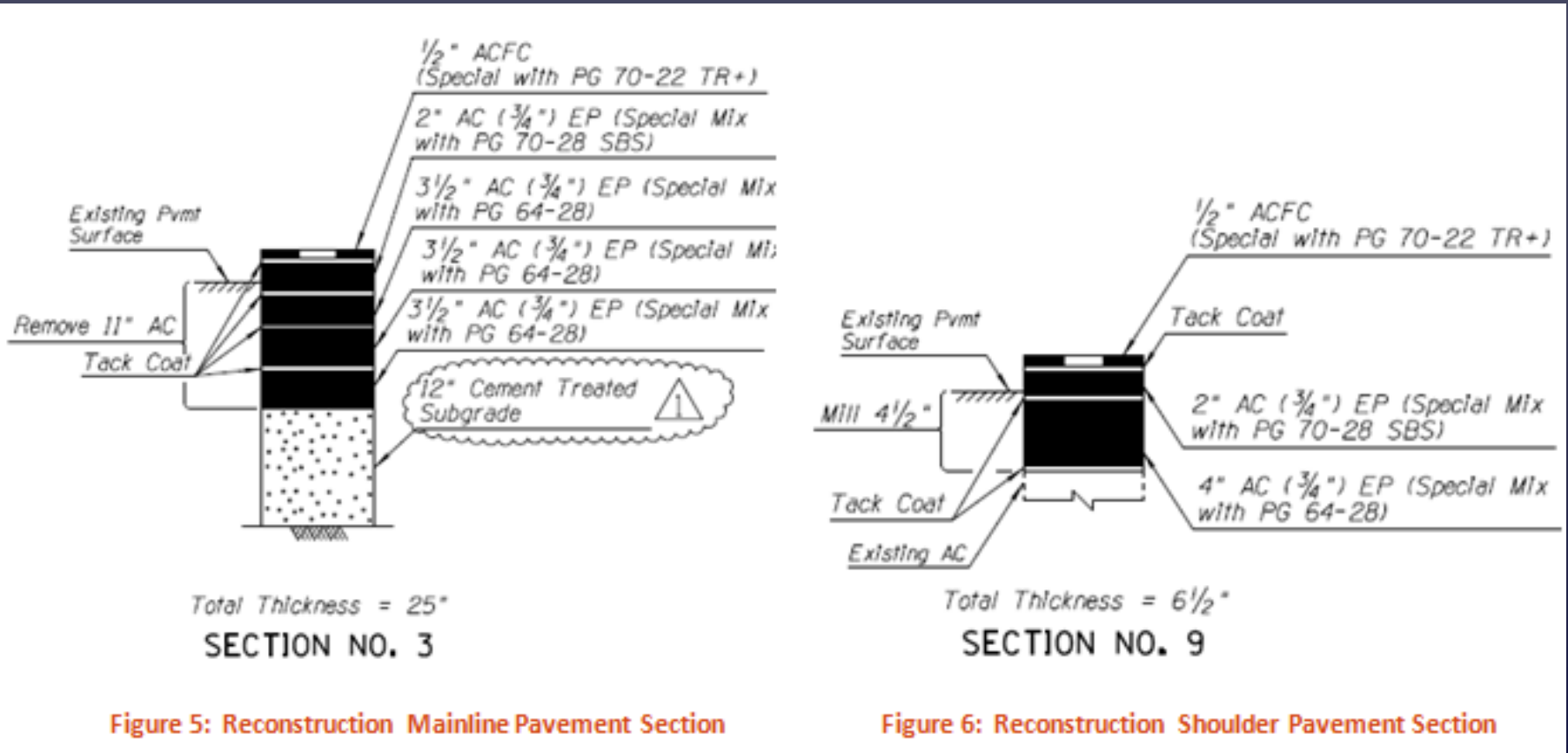

I-40 Cataract Lake Road to Parks TI

- Mill & Fill: Pavement Section

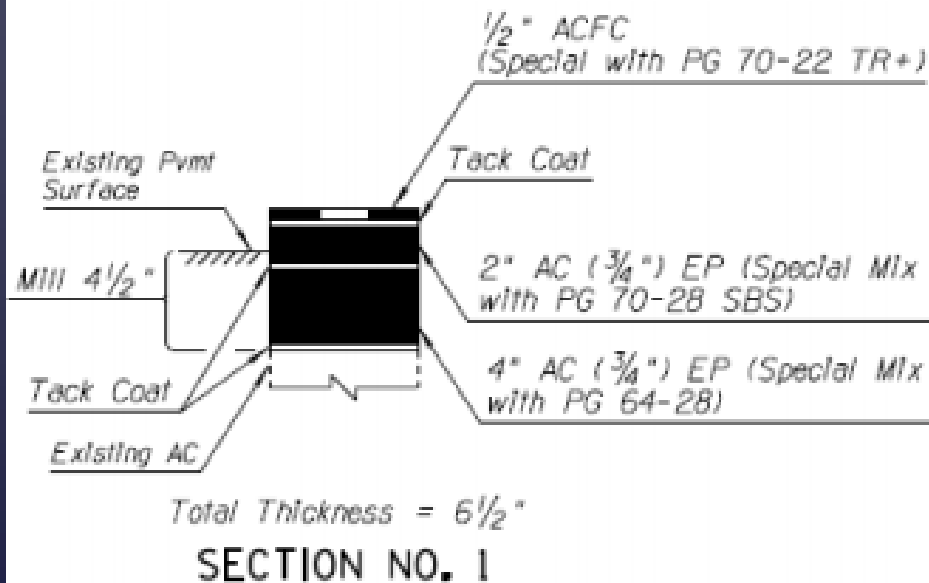

Figure 8: Mill & Fill Travel Lane Section

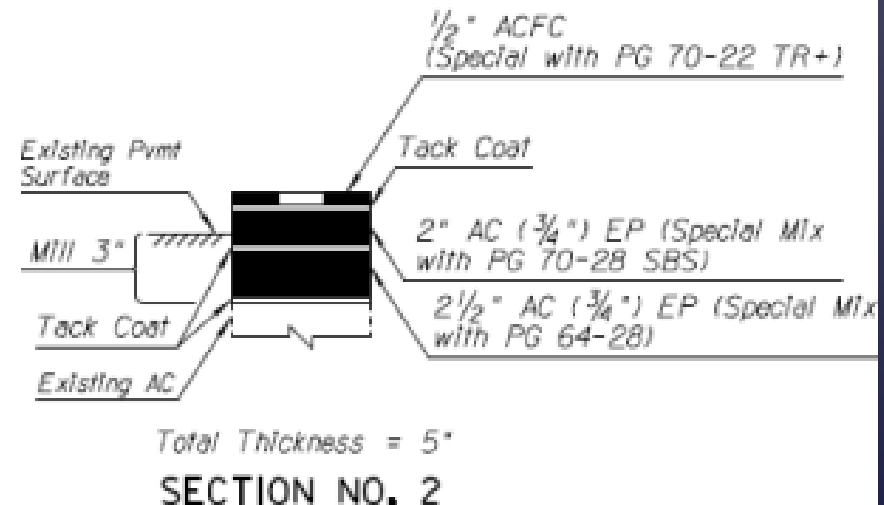

Figure 9: Mill & Fill Passing Lane and Shoulder Section

I-40 Cataract Lake Road to Parks TI

- Reconstruction: Cement Treated Subgrade



I-40 Cataract Lake Road to Parks TI

- Reconstruction: Cement Treated Subgrade
- Milled and removed (most) of existing AC
- Stockpiled RAP
- Moisture Conditioned
- Placed Portland Cement
- Processed with Reclamator
- Bladed
- Compacted
- Bladed to Grade
- Finished Rolled
- Applied Emulsion Seal Coat
- Induced Microfractures



I-40 Cataract Lake Road to Parks TI

- Reconstruction: 12" of Cement Treated Subgrade
- Pavement Structure: 12.5" of AC (recon.) - 6 inches of AC
 - Base Mixture
 - PG64-28
 - 25% RAP
 - Upper 2 Inches
 - PG70-28 (SBS)
 - 20% RAP
 - Effective Voids of 4.8%
 - Warm Mix
 - NCAT Test Section
 - Late Season paving



I-17 (NB) Coconino County Line to I-40

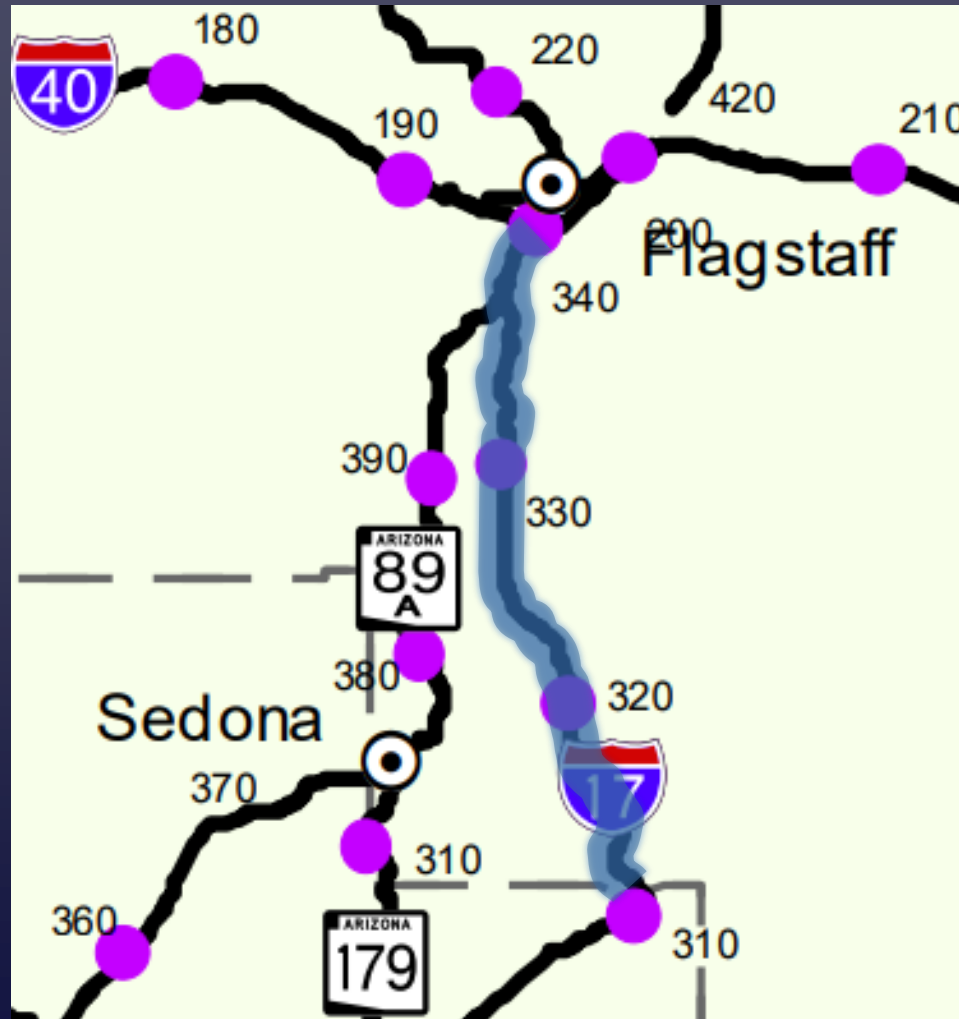

Increased Density - ADOT

- I-17 (NB) Coconino County Line to I-40 (old SR79)
 - Un-official FHWA Increased Density Demonstration Project
 - MP 312 to MP 340 (28 miles)
 - One Reconstruction Section - Geogrid Reinforced Subgrade
 - Near south end of project (2-1/4 miles)
 - Approximately 109,000 tons of End Product AC included in study



I-17 (NB) Coconino County Line to I-40

- Reconstruction: Geogrid Reinforced Subgrade
- Pavement Structure: 9" of AC (recon.) - 4.5" of AC
 - PG64-28
 - 15% RAP
 - Effective Voids of 5.5%

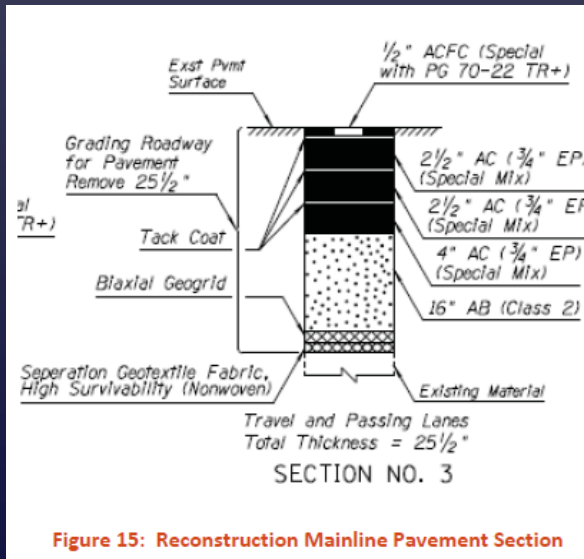

Baseline Projects (Standard Density)

- 2017 End Product AC (Statewide): 7.0% Target (9.0% max)
- 9,368 Cores
- Average In-Place Air Voids = 6.8% (93.2% Gmm)
- St.dev. = 1.36%
- **20% > 8.0% Air Voids**



ADOT End-Product AC Density

2017 Paving Projects

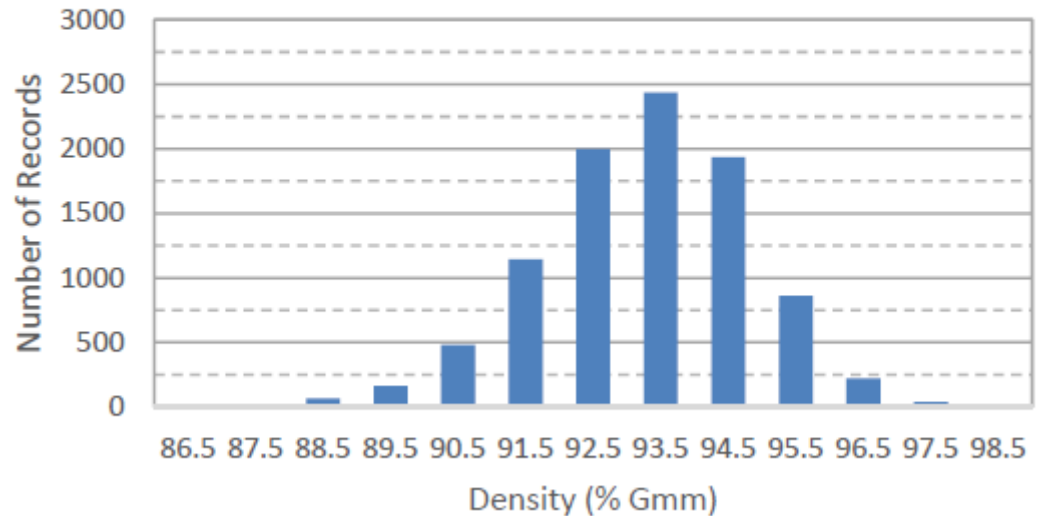

Select Projects (Standard Density)

- I-17 New River to Coldwater Canyon Road
 - Average In-Place Air Voids = 6.1%
 - St. Dev. = 1.02%
- I-40 Parks TI to Riordan Bridge
 - Average In-Place Air Voids = 6.0%
 - St. Dev. = 1.06%
 - ADOT's first project with SBS polymer modified asphalt in dense graded AC (east of the Bellemont, EB & WB)
- I-40 Walnut Canyon to Twin Arrows
 - Average In-Place Air Voids = 5.9%
 - St. Dev. = 1.07%
 - ADOT's first project utilizing Intelligent Compaction

Standard Density

ADOT End-Product AC Density 2017 Paving Projects

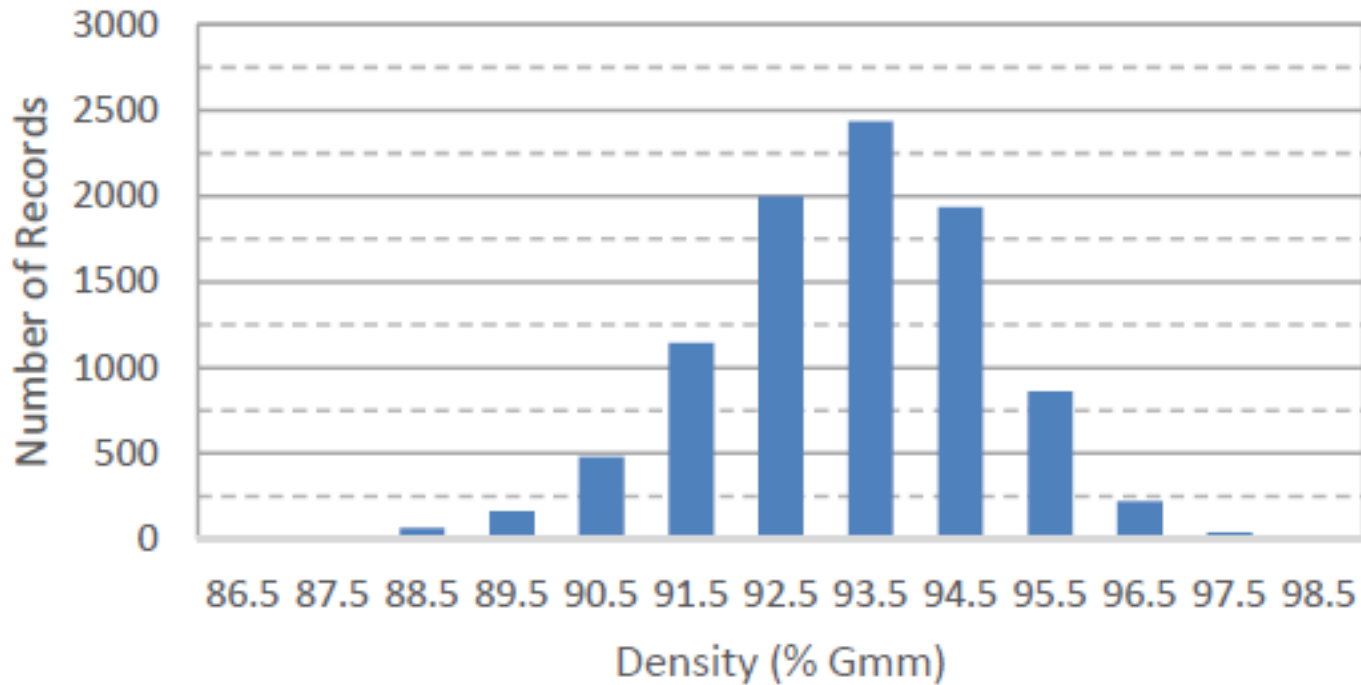

Increased Density

ADOT End-Product AC Density

2018 Increased Density Projects (thru 12/05/18)

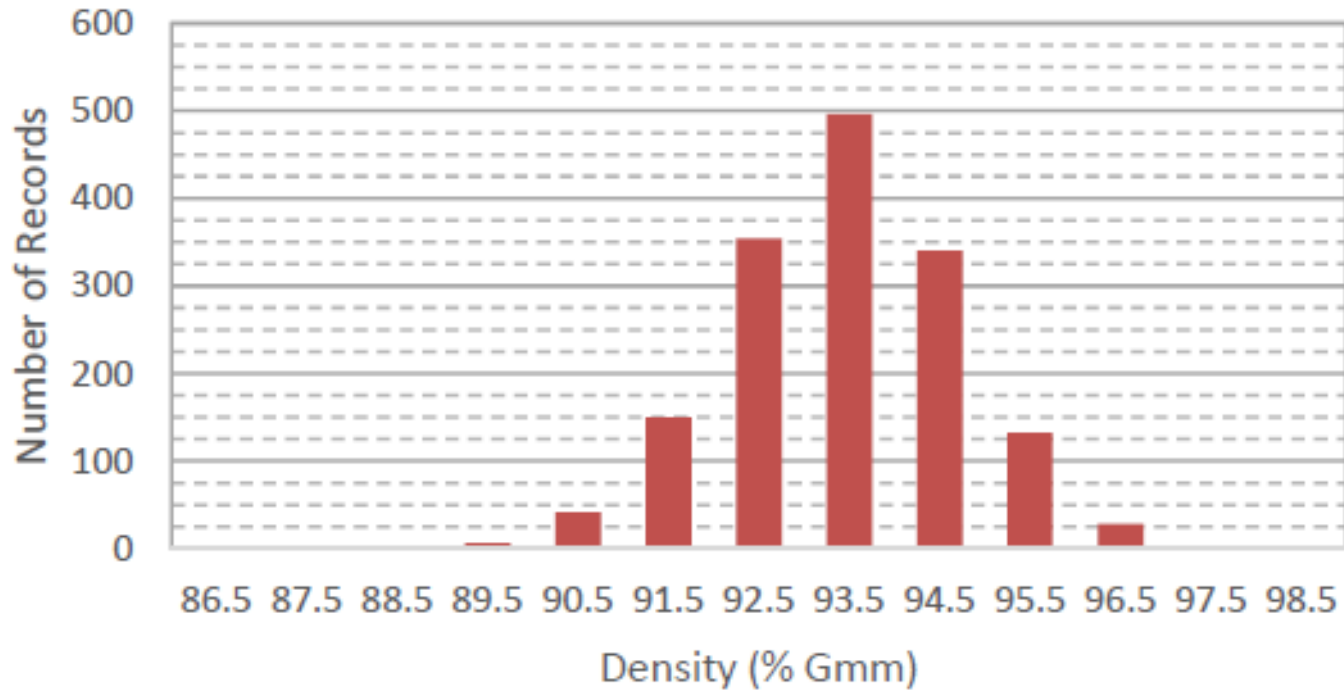

Standard & Increased Density

ADOT End-Product AC Density

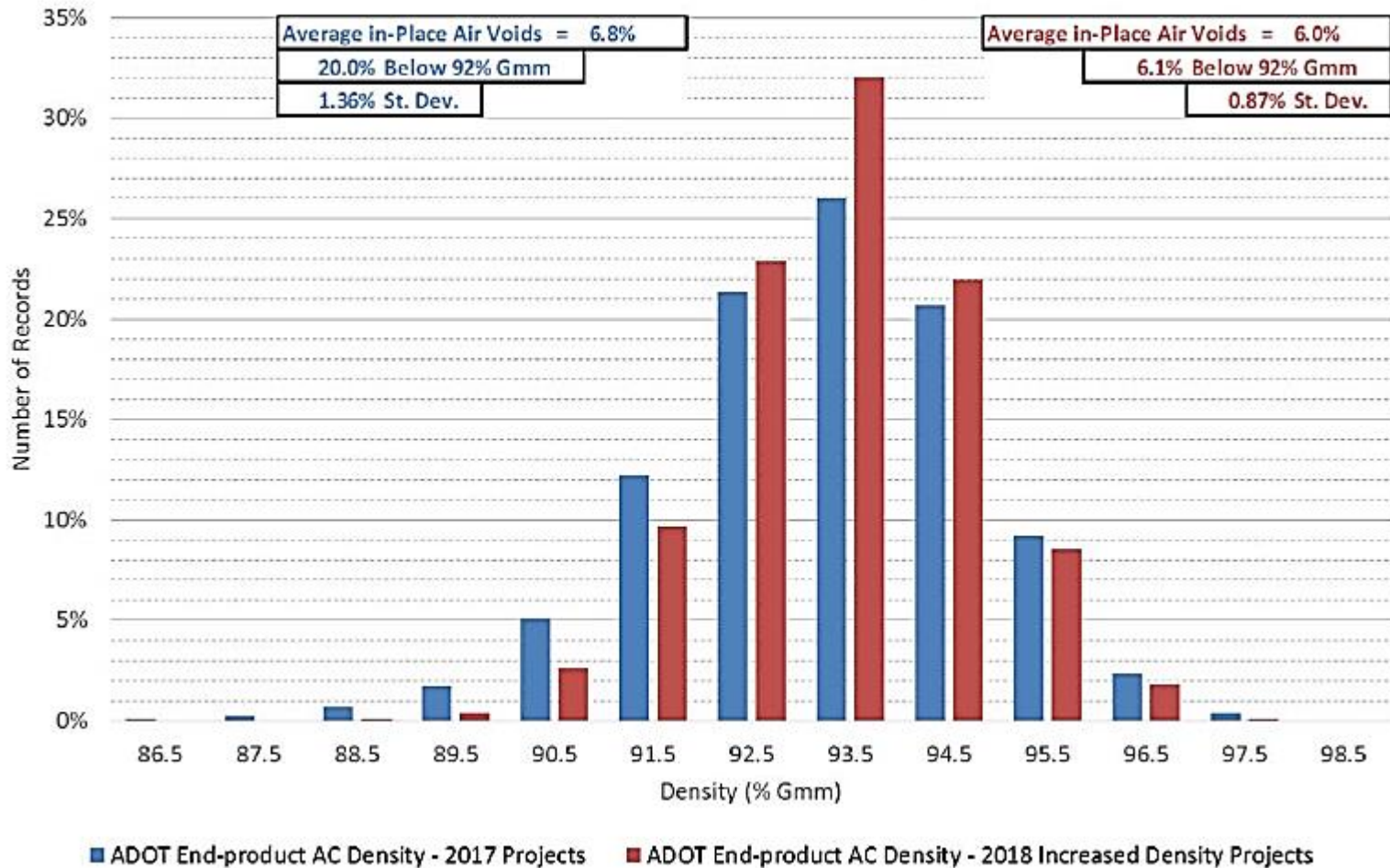

Increased Density

Mix Design Properties	I-40			I-17
Binder Grade	PG64-28	PG70-28(SBS)	PG64-28	PG64-28
Binder Content (%)	5.3	5.2	5.5	5.0
RAP Aggregate Content (%)	20	20	25	15
RAP Binder (% of asphalt binder)	15.2	15.5	20.0	12.4
Mineral Admixture	1% Lime	1% Lime	1% Lime	1% Lime
Effective Mix Voids (%)	4.8	4.9	4.8	5.5, 5.6
Average in-Place Air Voids (%)	5.8	6.0	6.0	6.1
Average Standard Deviation (%)	0.88	0.92	0.92	0.80
Number of Cores (n)	280	70	610	589

Increased Density (I-40 Cataract)

PU of 96 Lots
I-40 Cataract Lake to Parks TI

■ PU of 100 ■ PU of 95 to 99 ■ PU of 90 to 94 ■ PU of 50 to 89 ■ Reject

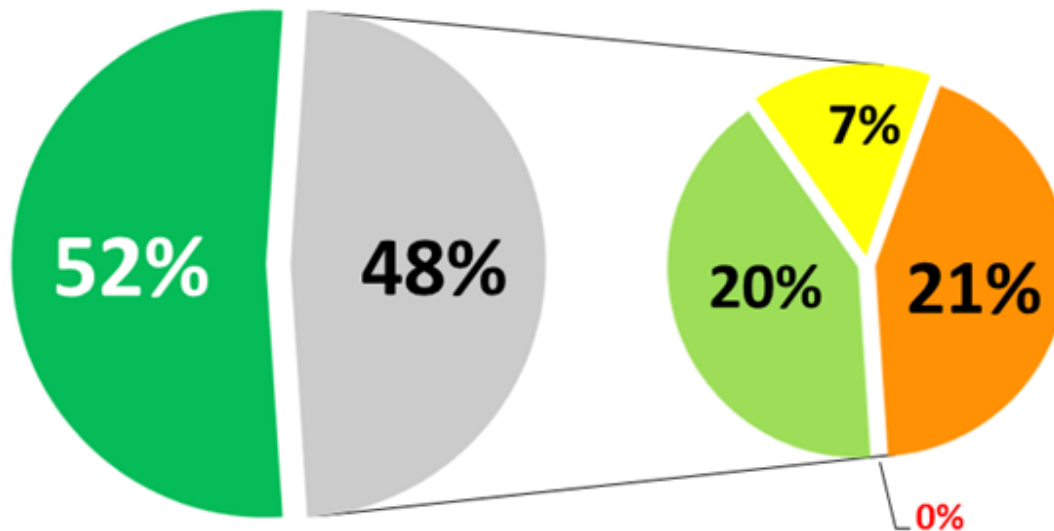

Increased Density

PU of 59 Lots

I-17 Coconino County Line to I-40

■ PU of 100 ■ PU of 95 to 99 ■ PU of 90 to 94 ■ PU of 50 to 89 ■ Reject

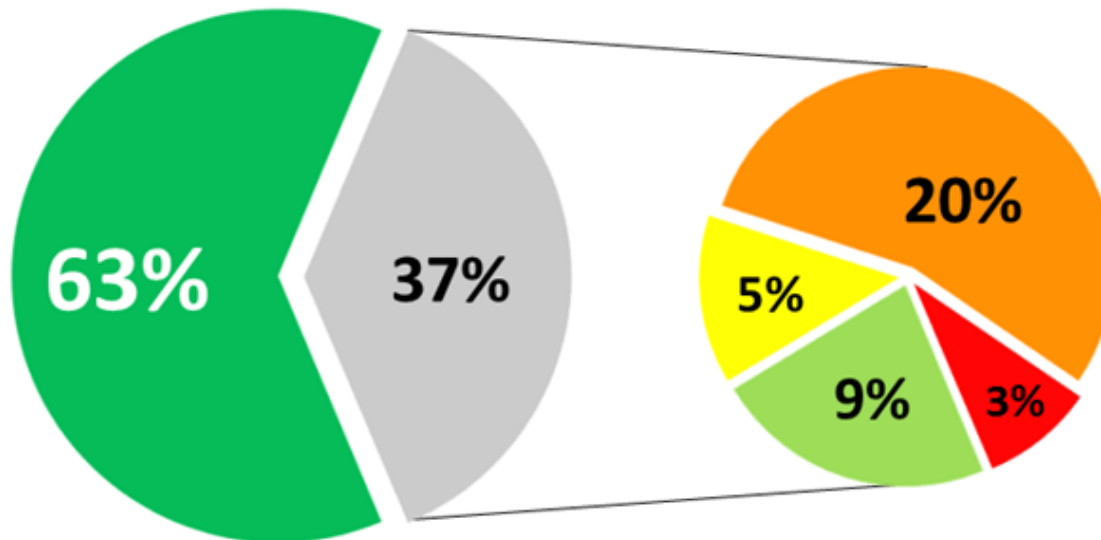

Increased Density

PL of 96 Lots

I-40 Cataract Lake to Parks TI

■ PL of 100 ■ PL of 95 to 99 ■ PL of 90 to 94 ■ PL of 50 to 89 ■ Reject

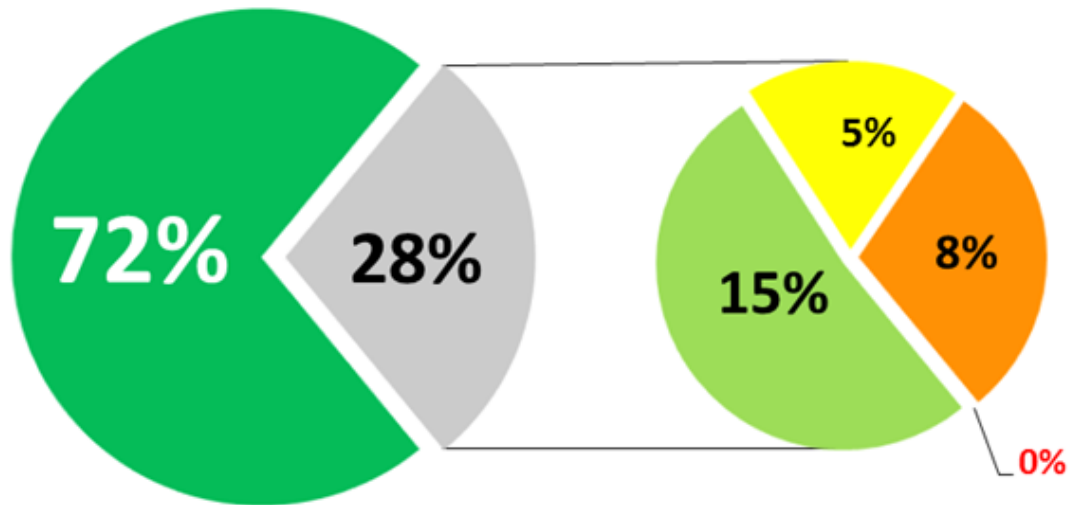

Increased Density

PL of 59 Lots

I-17 Coconino County Line to I-40

■ PL of 100 ■ PL of 95 to 99 ■ PL of 90 to 94 ■ PL of 50 to 89 ■ Reject

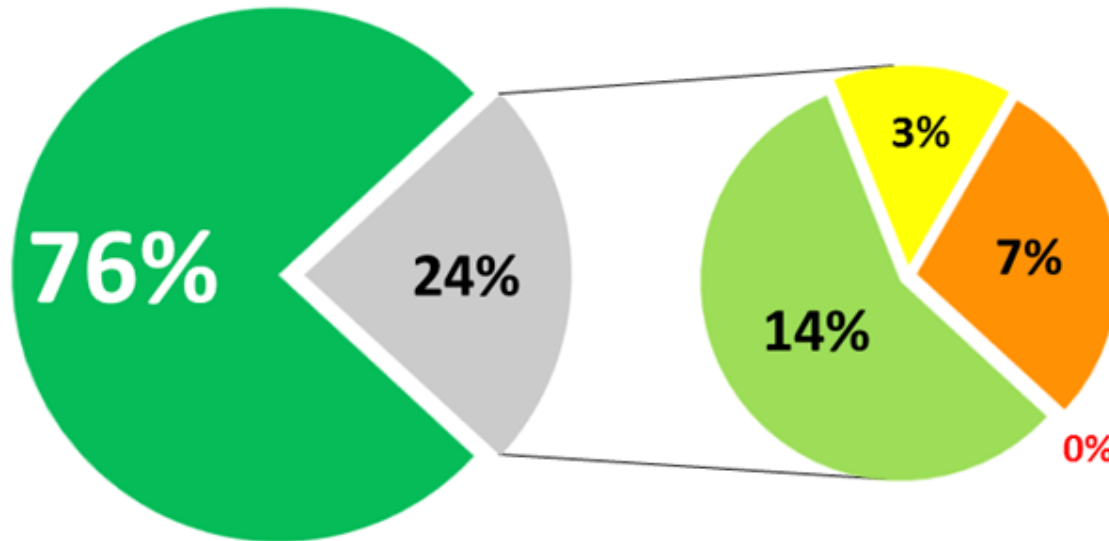

Increased Density achieved with:

- 13 Different Mix Designs
 - 3 different mix design laboratories
 - 5 different PGs (3 different asphalt suppliers)
 - 5 different Aggregate Sources
 - 2 different anti-strip Mineral Admixtures (provided by three different suppliers)
- Produced with/without Warm Mix Additive
 - Production temperature as low as 265 deg. F
 - Used as a compaction aid at typical production temp.
- Varying AC Lift Thickness and Compaction Tools
 - Lifts varied from 2" to 5" thick
 - With/without Intelligent Compaction

Increased Density achieved with:

- AC placed for both Reconstruction and Mill/Fill
 - Cement Treated Subgrade
 - Geogrid-Reinforced Subgrade
- AC placed during Different Seasons
 - Mid Summer in Desert
 - Mid December near 7,000 ft. elevation
- Five Different Projects
- Three Different Contractors
 - Different Hot Plants / Equipment / Personnel
- **Reduced interconnected air voids at/above 8.0% in-place air voids by 70% (20% -> 6.1%)**
- **Reduced Standard Deviation by 36% (1.36% -> 0.87%)**

FHWA Increased Density Demonstration Project(s)

Thank you

Questions?

Nye McCarty, P.E.
NMcCarty@azdot.gov
(928) 779-7522